



Documentation:

RoboRoc® Robot Dress Pack System

Customer: Fanuc Japan

Date: 26-04-2026

Robot: Fanuc R2000/E_210F

System: RoboRoc® Robot Dress Pack System

Variant / Configuration: RoboRoc kk

Kit/Part No.: K.EP.F343.70.16-0001

Dress Pack / Routing Scope: A1-S/S-A6

Application: Empty Dresspack

Project / Line: Not applicable

Document Type: Final technical documentation

Revision: 00

Becker Account Manager: Aniruddha Joshi

Scope

This documentation describes the **RoboRoc® Robot Dress Pack System** supplied by Becker as a **mechanically guided energy and media routing system for industrial robots**.

The documentation covers:

- System identification
- Safety precautions
- Installation, adjustment, and optimization
- Maintenance and repair instructions
- Spare and wear parts

The RoboRoc system allows **controlled mechanical adjustment** to adapt routing behavior to the specific robot, application, and installation environment.

System Description (RoboRoc)

The RoboRoc system is a mechanically guided dress pack solution designed to route supply lines between defined robot axes using a rigid frame, guided corrugated tubing, support elements, and spring-assisted guidance.

The system enables:

- Defined routing paths
- Mechanical optimization of bend behavior
- Adaptation to different robot geometries and applications

Final routing behavior is achieved by **adjustment and optimization during installation.**

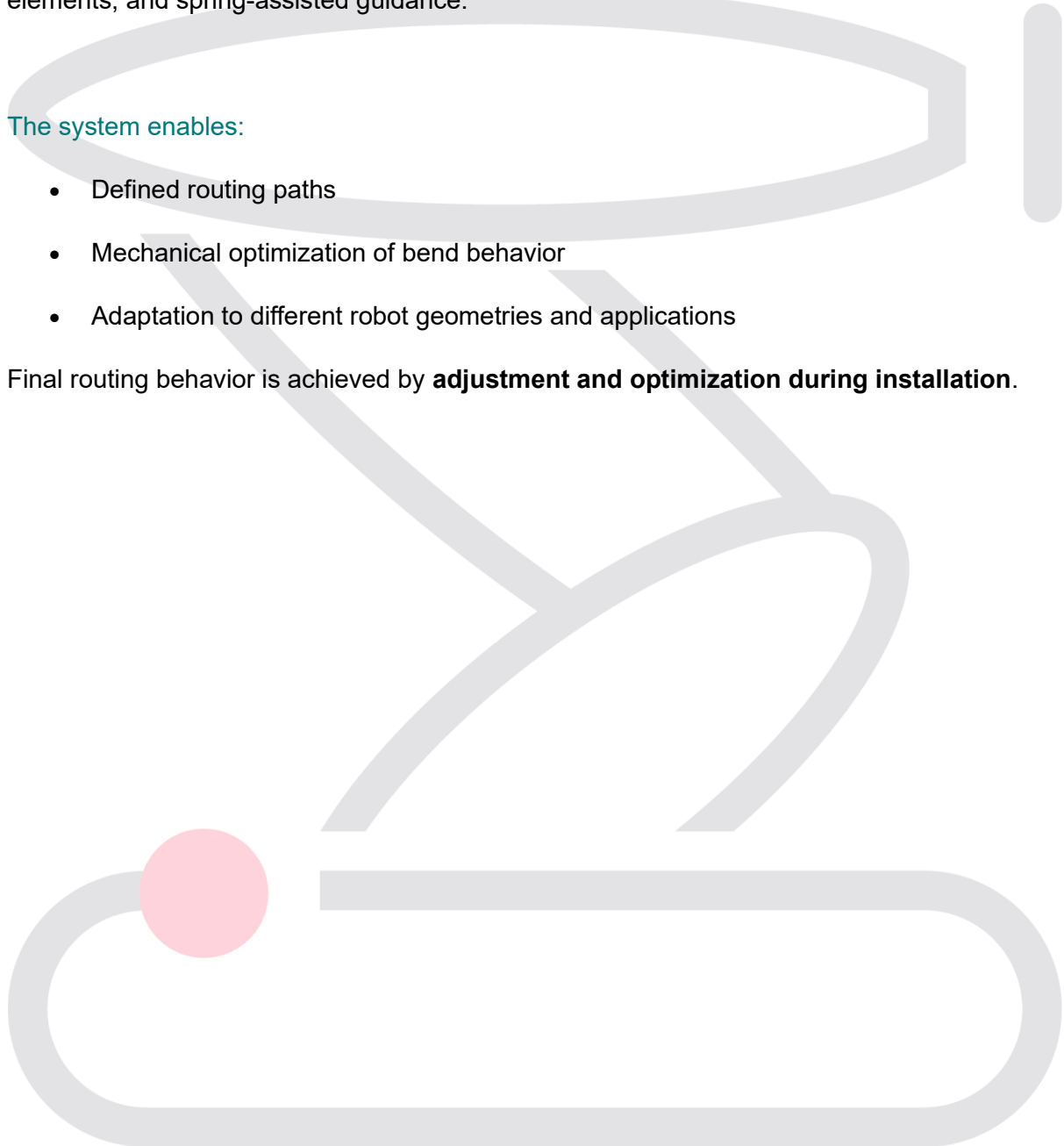

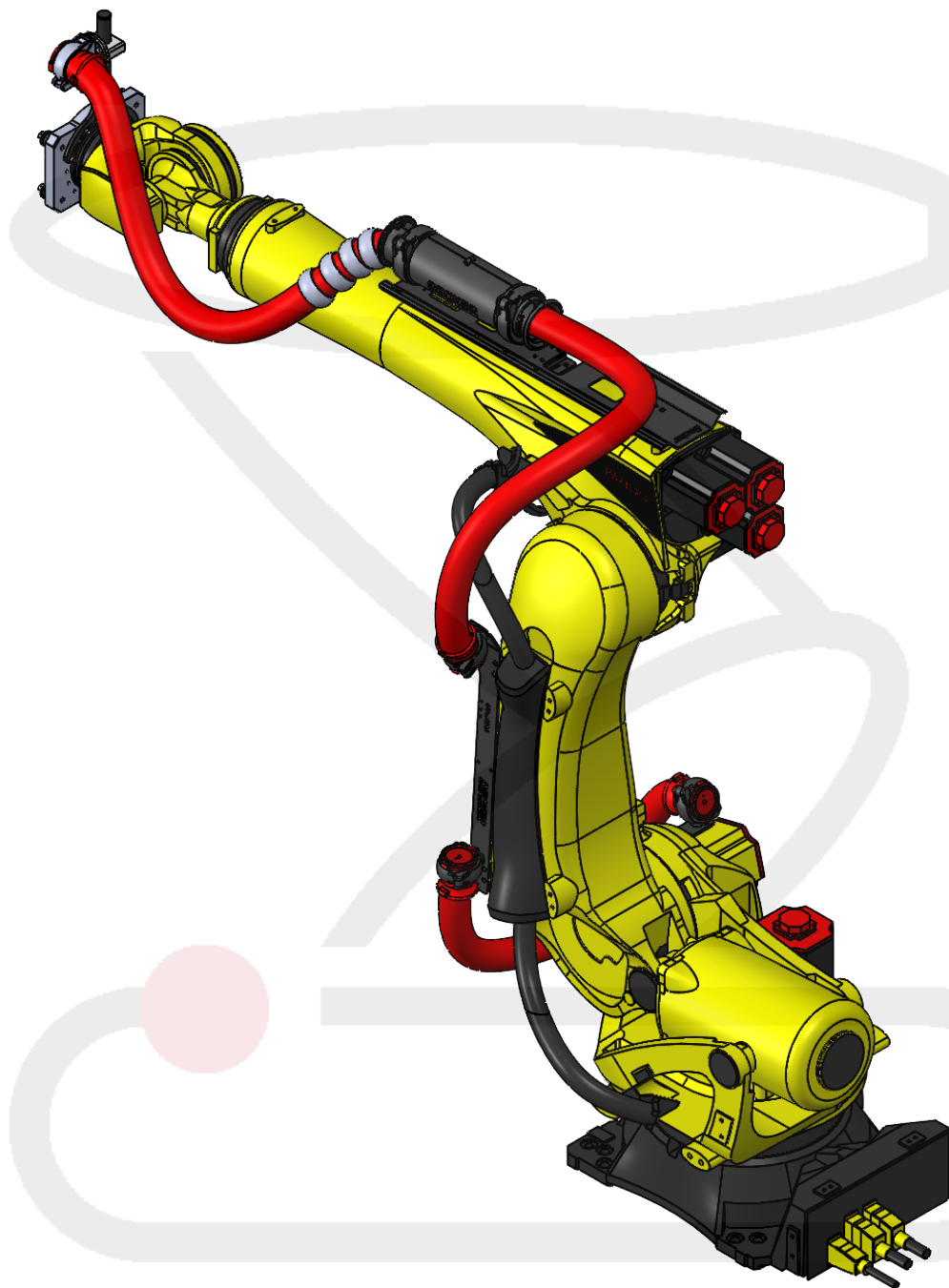

General tolerance according to DIN ISO 2768-1K Edges of undefined shape according to DIN ISO 13715 General tolerances for welded constructions according to DIN EN ISO 13920-C General tolerances for laser cutting according to DIN EN ISO 9013-1			scale : 1:1	weight: kg
			material :-	
	Date	Name	dokument typ: assembly drawing	
drawn	04-22-2026	ASM	title: Fanuc Japan	
checked	04-22-2026	AJO	A1-S/S-A6 , NW70	
unit (mm)			Fanuc R2000/E_210F	
Protection notice DIN ISO 16016: The reproduction, distribution and utilization of this document as well as the communication of its contents to others without express authorization is prohibited. Offenders will be held liable for the payment of damages. All rights reserved in the event of the grant of a patent, utility model or design.			BECKER Robotic	drawing-no.: K.EP.F343.70.16-0001
			A4	4

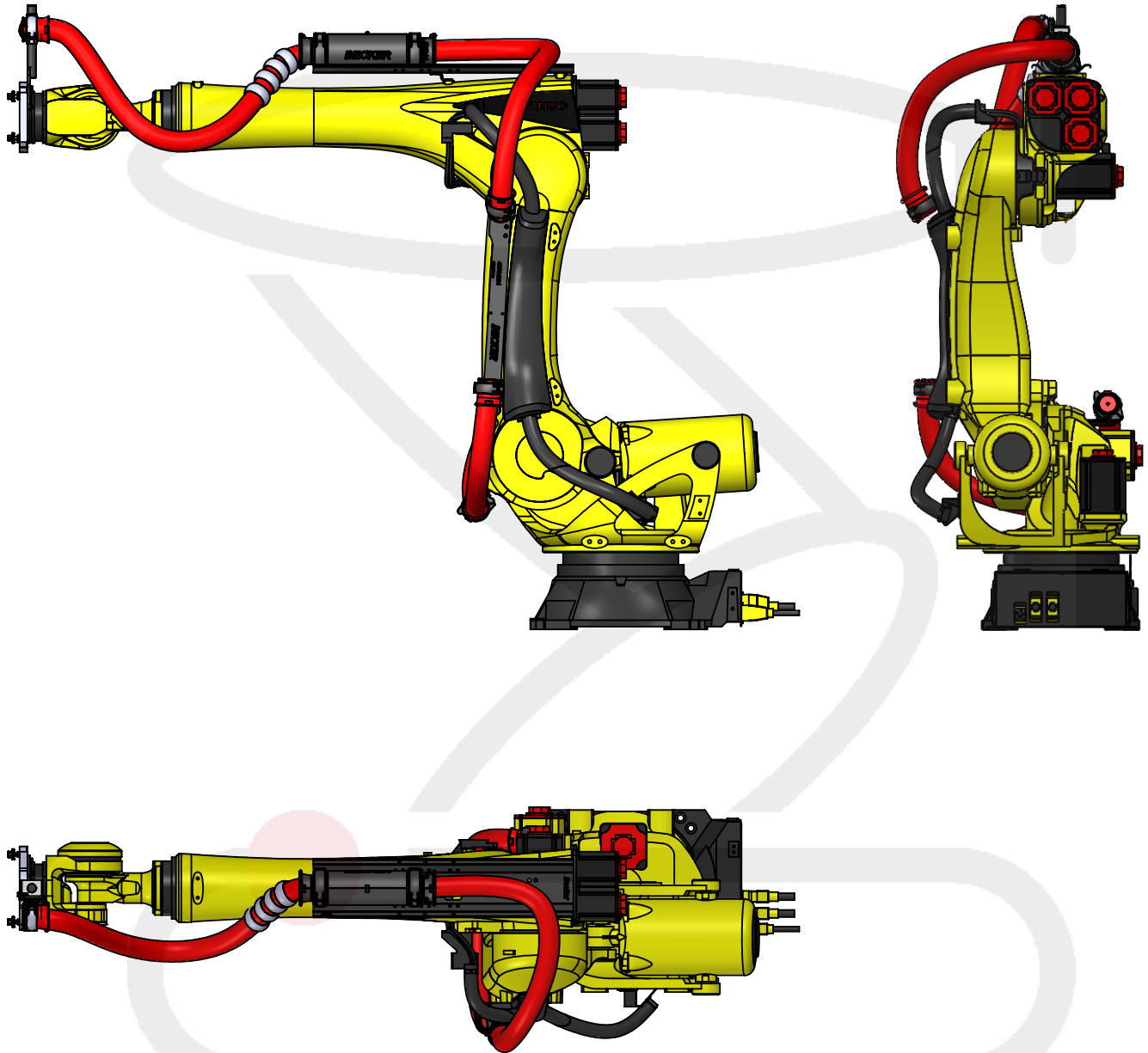

General tolerance according to DIN ISO 2768-FK Edges of undefined shape according to DIN ISO 13715 General tolerances for welded constructions according to DIN EN ISO 13920-C General tolerances for laser cutting according to DIN EN ISO 9013-1		scale : 1:1	weight: kg		
		material :-			
	Date	Name	dokument typ: assembly drawing		
drawn	04-22-2026	ASM	title: Fanuc Japan A1-S/S-A6 , NW70 Fanuc R2000/E_210F		
checked	04-22-2026	AJO			
unit (mm)			drawing-no.:		
Protection notice DIN ISO 16016: The reproduction, distribution and utilization of this document as well as the communication of its contents to others without express authorization is prohibited. Offenders will be held liable for the payment of damages. All rights reserved in the event of the grant of a patent, utility model or design.			K.EP.F343.70.16-0001	A4	5

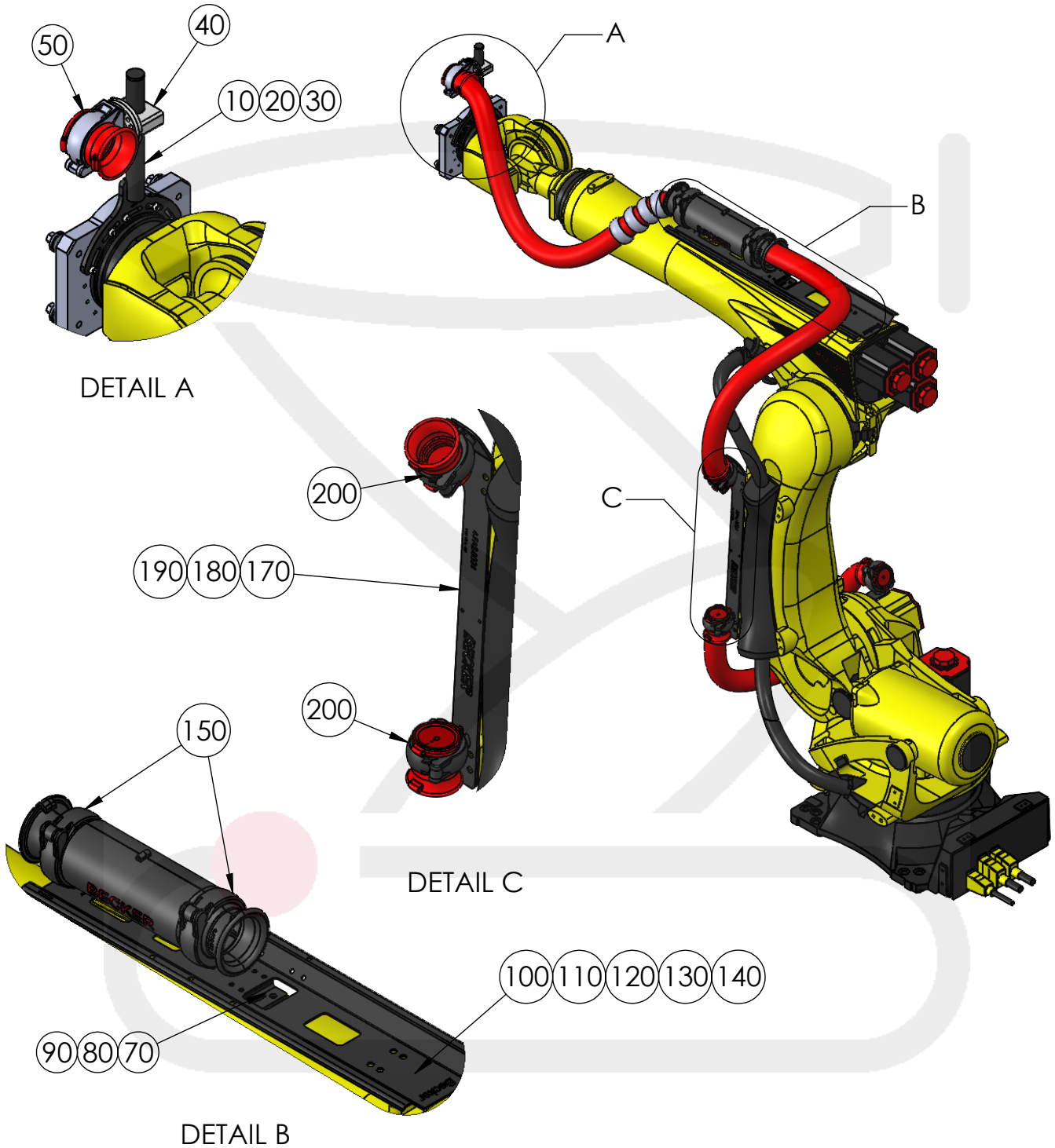

General tolerance according to DIN ISO 2768-K Edges of undefined shape according to DIN ISO 13715 General tolerances for welded constructions according to DIN EN ISO 13920-C General tolerances for laser cutting according to DIN EN ISO 9013-1			scale : 1:1	weight: kg
			material :-	
	Date	Name	dokument typ: assembly drawing	
drawn	04-22-2026	ASM	title: Fanuc Japan	
checked	04-22-2026	AJO	A1-S/S-A6 , NW70	
unit (mm)			Fanuc R2000/E_210F	
			drawing-no.:	
<p>Protection notice DIN ISO 16016: The reproduction, distribution and utilization of this document as well as the communication of its contents to others without express authorization is prohibited. Offenders will be held liable for the payment of damages. All rights reserved in the event of the grant of a patent, utility model or design.</p>			K.EP.F343.70.16-0001	A4 6

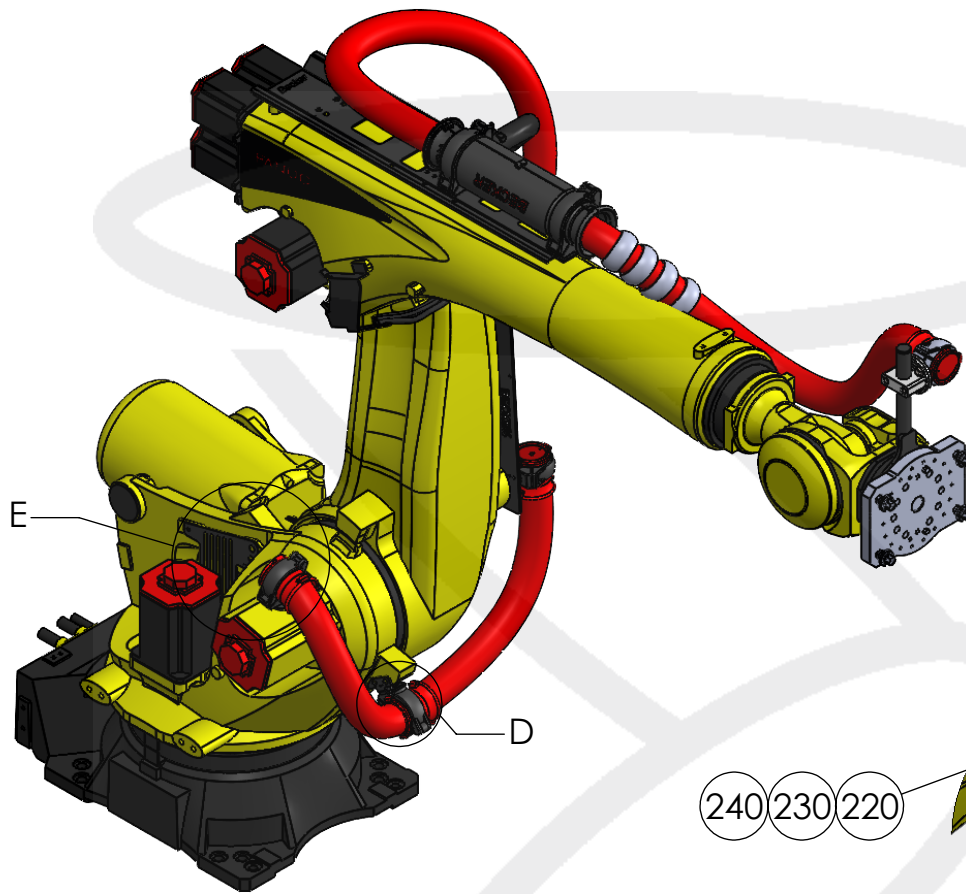

240 230 220

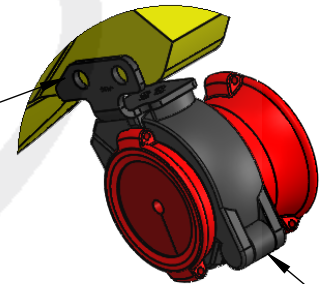

250

360 350 340 330 320

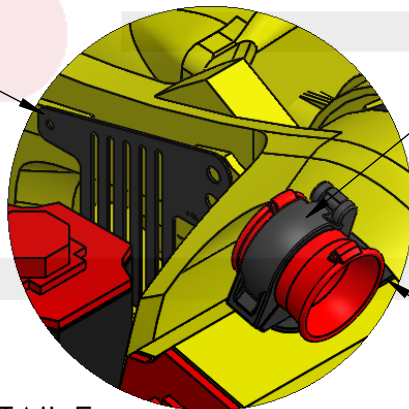



300

270 280 290

DETAIL D

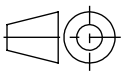
DETAIL E

General tolerance according to DIN ISO 2768-K Edges of undefined shape according to DIN ISO 13715 General tolerances for welded constructions according to DIN EN ISO 13920-C General tolerances for laser cutting according to DIN EN ISO 9013-1			scale : 1:1	weight: kg	
material :-					
	Date	Name	dokument typ: assembly drawing		
drawn	04-22-2026	ASM	title: Fanuc Japan		
checked	04-22-2026	AJO	A1-S/S-A6 , NW70		
unit (mm)			Fanuc R2000/E_210F		
			drawing-no.:		
			K.EP.F343.70.16-0001		A4

Protection notice DIN ISO 16016: The reproduction, distribution and utilization of this document as well as the communication of its contents to others without express authorization is prohibited. Offenders will be held liable for the payment of damages. All rights reserved in the event of the grant of a patent, utility model or design.

Axis 6

corrugated tube NW70 = 4.702.768-1
3200

Link Arm

Part no.

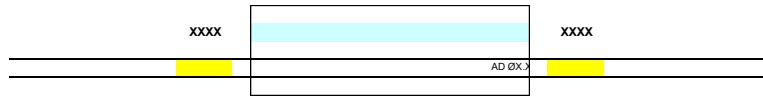

Part no.



Notes:

+40 addition for pre-cut (not relevant to the total length)
tolerance range -0/+1%

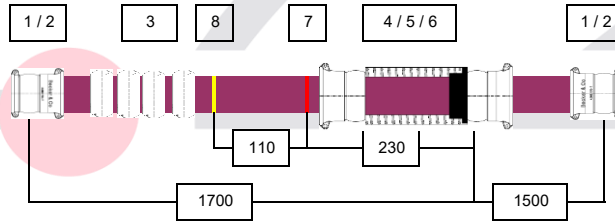

No.	Description	Part No.
1	Ball with trumpet, crossover for NW70	4.090.170-T
2	Clamping ring Øxmm for ball NW70	4.117.82x-2
3	4x protector for NW70	4.702.100-1
4	Pressure spring for NW70	4.DRK.070-001
5	Spring counter bracket for NW70 Short	4.117.426-1
6	RoboRoc tube for NW70	4.600.270-1-A
7	Position marker NW70, red	4.770.001-RD
8	Position marker NW70, yellow	4.770.001-YE

Application		Empty Dresspack	Created	04-20-2026	AMO	Document type: electrical drawing		
Robot		Fanuc R2000/E_210F	Checked	04-20-2026	AJO	Customer: FANUC JAPAN		
Kit Number		K.EP.F343.70.16-0001	Revision No.		00	Project: Empty Dresspack A1-S / S-A6		
			unit (mm)			drawing-no.:		
Protection notices DIN ISO 16016: The reproduction, distribution and utilization of this document as well as the communication of its contents to others without express authorization is prohibited. Offenders will be held liable for the payment of damages. All rights reserved in the event of the grant of a patent, utility model or design						4.000.1476		A4
								9

Link Arm

corrugated tube NW70 = 4.702.768-1
1400

Axis 1

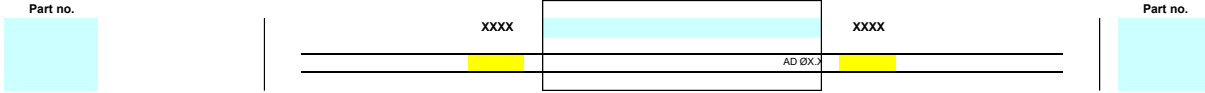

Notes:

+40 addition for pre-cut (not relevant to the total length)
tolerance range -0/+1%

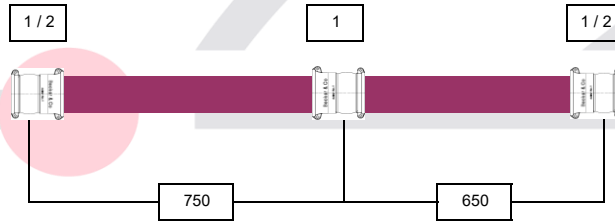

No.	Description	Part No.
1	Ball with trumpet, crossover for NW70	4.090.170-T
2	Clamping ring Øxmm for ball NW70	4.117.82x-2

Application		Empty Dresspack	Created	04-20-2026	AMO	Document type: electrical drawing			
Robot		Fanuc R2000/E_210F	Checked	04-20-2026	AJO	Customer: FANUC JAPAN			
Kit Number		K.EP.F343.70.16-0001	Revision No.		00	Project: Empty Dresspack A1-S / S-A6			
		unit (mm)				drawing-no.:			
						4.000.1472		A4	10
Protection notices DIN ISO 16016: The reproduction, distribution and utilization of this document as well as the communication of its contents to others without express authorization is prohibited. Offenders will be held liable for the payment of damages. All rights reserved in the event of the grant of a patent, utility model or design									

General Notes and Applicable Standards

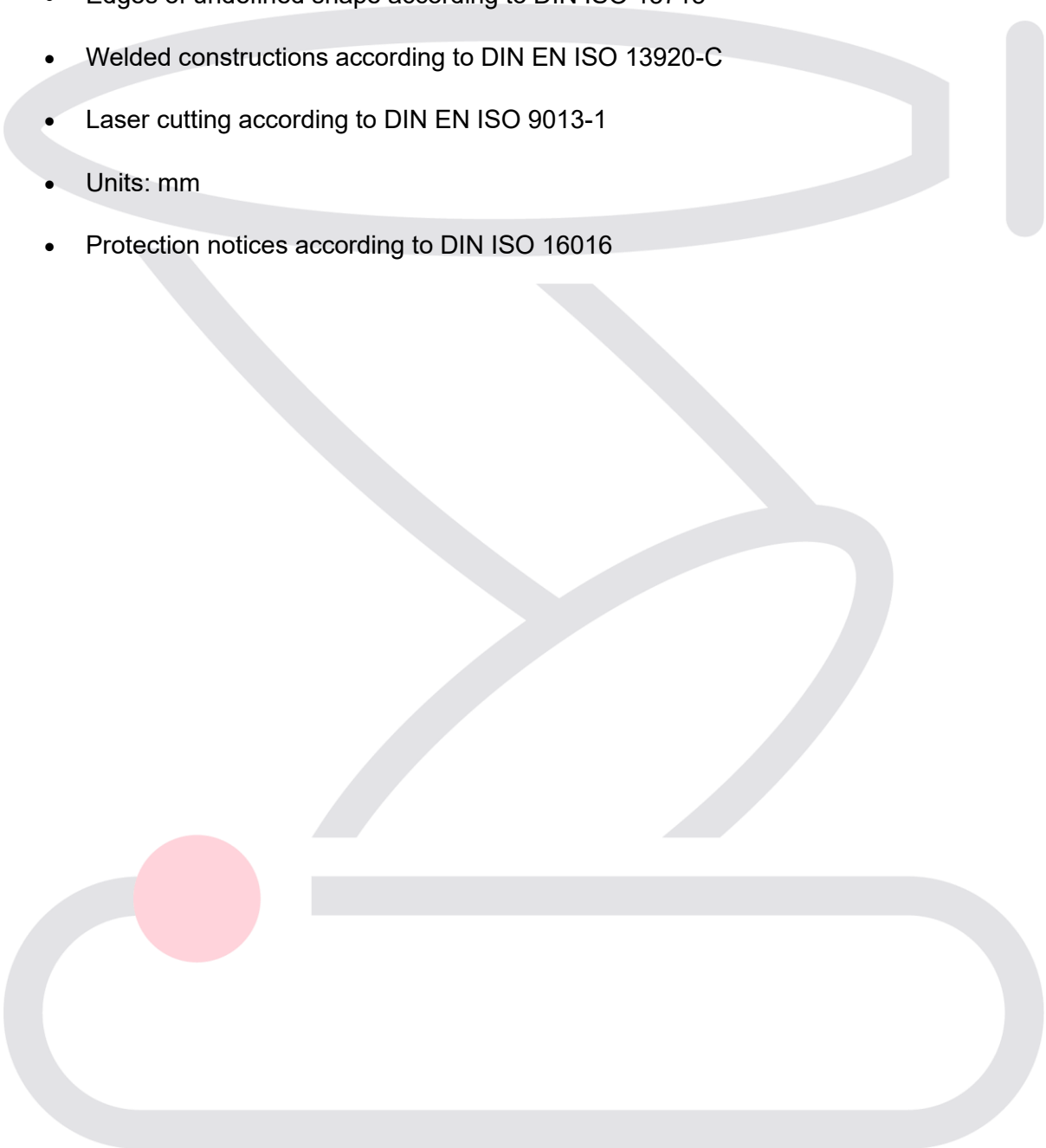
- General tolerances according to DIN ISO 2768-fK
 - Edges of undefined shape according to DIN ISO 13715
 - Welded constructions according to DIN EN ISO 13920-C
 - Laser cutting according to DIN EN ISO 9013-1
 - Units: mm
 - Protection notices according to DIN ISO 16016
- 

Safety Precautions

Please carefully read and always follow the precautions stated below.

When working on the robot, always refer to the robot manufacturer's manual.

General

- The RoboRoc system is intended exclusively for industrial applications.
- Installation, operation, and service only by authorized and trained personnel.
- Disconnect electrical power and depressurize media lines before work.
- Entry into the robot operating space is prohibited while power or pressure is applied.
- Wear appropriate personal protective equipment (PPE).

Lubrication / Cable Grease

For technical reasons, supply lines inside the corrugated tubing are lubricated with cable grease.

- Never swallow the grease; avoid skin and eye contact and inhalation of vapors.
- Spilled grease may cause slip hazards.
- Prevent discharge into drains, sewers, or open waters.
- Wear oil-resistant protective gloves during handling.
- Grease applied: **Optitemp RB 2 – Supplier: Castrol**

Pinch Points

Due to mechanical design characteristics, pinch hazards may occur during installation and adjustment.

- Always wear robust safety gloves.
- Installation and adjustment only by qualified personnel.

Spring Stroke

Pressure springs may cause injury hazards due to sudden release of spring force.

- Always wear robust safety gloves.
- Handle spring elements carefully during installation and adjustment.
- Installation and adjustment only by qualified personnel.

Length and Weight

Because of system length and weight, there is a risk of injury during handling and installation.

- If possible, installation should be performed by two authorized persons.
- Secure the dress pack during handling to avoid uncontrolled movement.

Installation & Adjustment

The RoboRoc system is installed mechanically at defined robot interfaces and **requires adjustment and optimization** to achieve stable routing behavior.

Minimum Bending Radius of Corrugated Tube

The minimum bending radii for the corrugated tube **must not be undercut**.

Becker Art.-No.	Nominal Width	Static [mm]	Dynamic [mm]
4.702.368-1	NW 36	81	191
4.702.480-1	NW 48	102	237
4.702.768-1	NW 70	140	330
4.702.910-1	NW 90	150	400

The corrugated tube must **not rub** on:

- Robot components
- Equipment
- Body or structural components

In case of breakage, a **protector and connector** may be used to connect the corrugated tube ends.

Adjustment – RoboRoc Frame

By displacing the RoboRoc baseplate, the bend between **axis 3 and axis 6** can be adjusted.

- Adjustment range:
 - ± 200 mm (standard tube)
 - ± 100 mm (KK tube)

Design:

The baseplate is fastened using four **M8 × 14** hexagon head screws and four sliding nuts.

The center position is marked by engraving on the baseplate.

The robot program should be run for the first time using this center position.

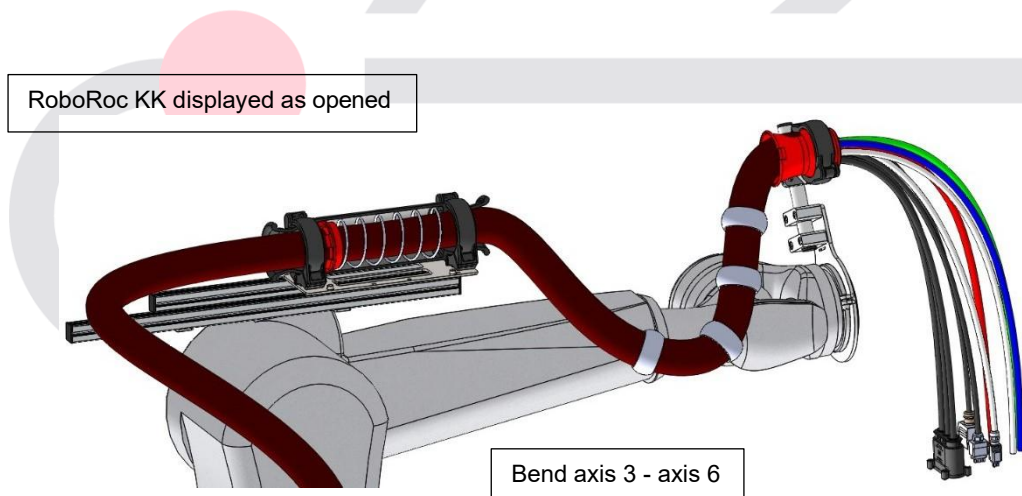
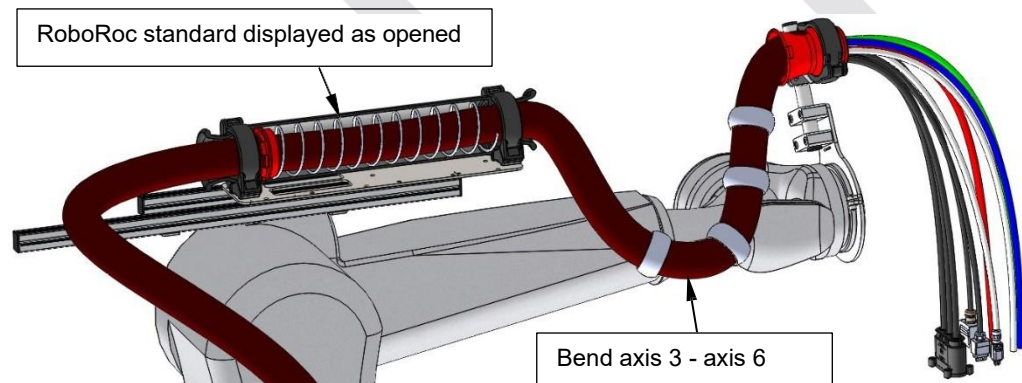

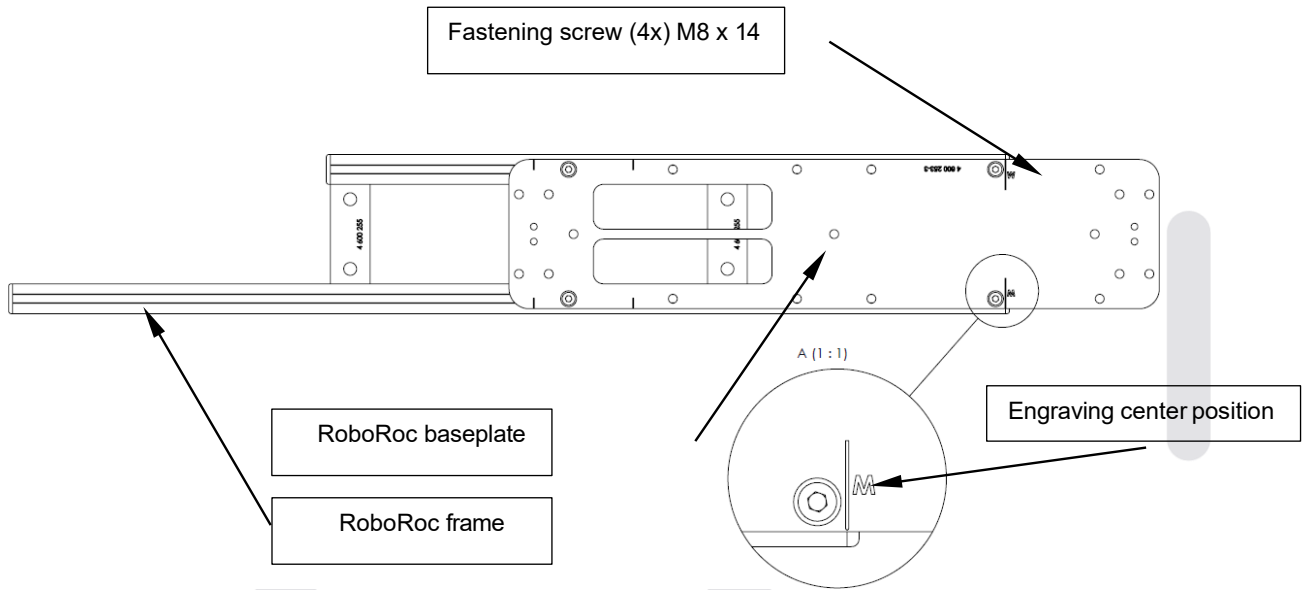

Adjustment – RoboRoc Standard Frame

Optimization +200 mm (extend bend A3–A6):

- Loosen four M8 × 14 screws (SW 6)
- Move baseplate toward axis 6
- Insert front screws into alternate bore

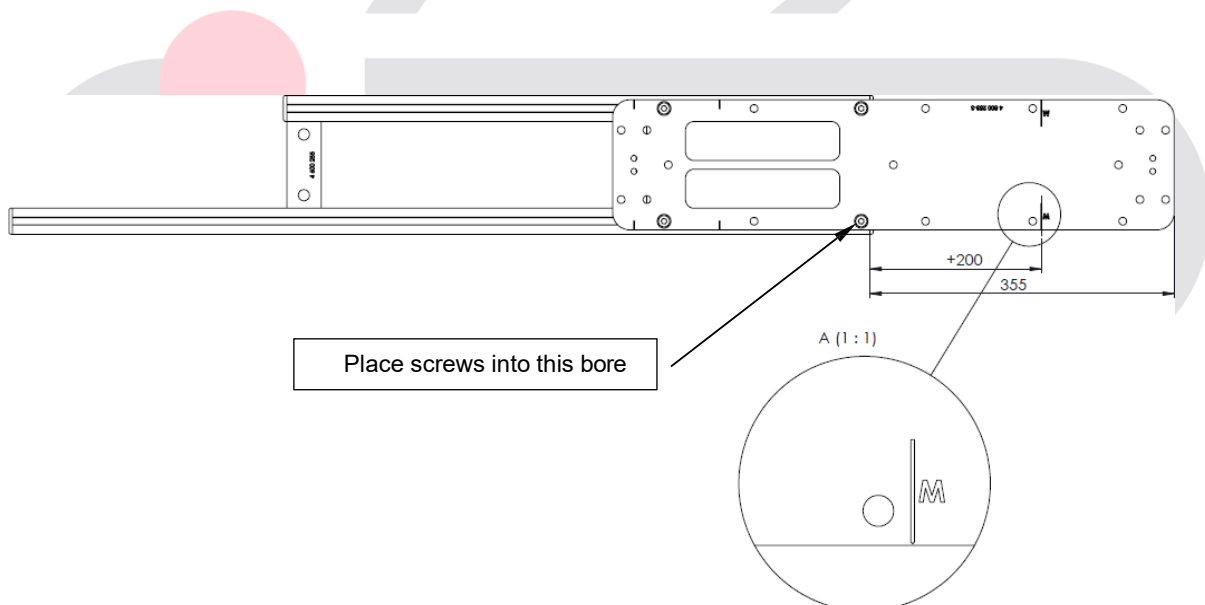

Optimization -200 mm (shorten bend A3–A6):

- Loosen screws
- Move baseplate away from axis 6

⚠ Ensure the dress pack does not fall over the profile deposit, especially when axis 3 is stretched.

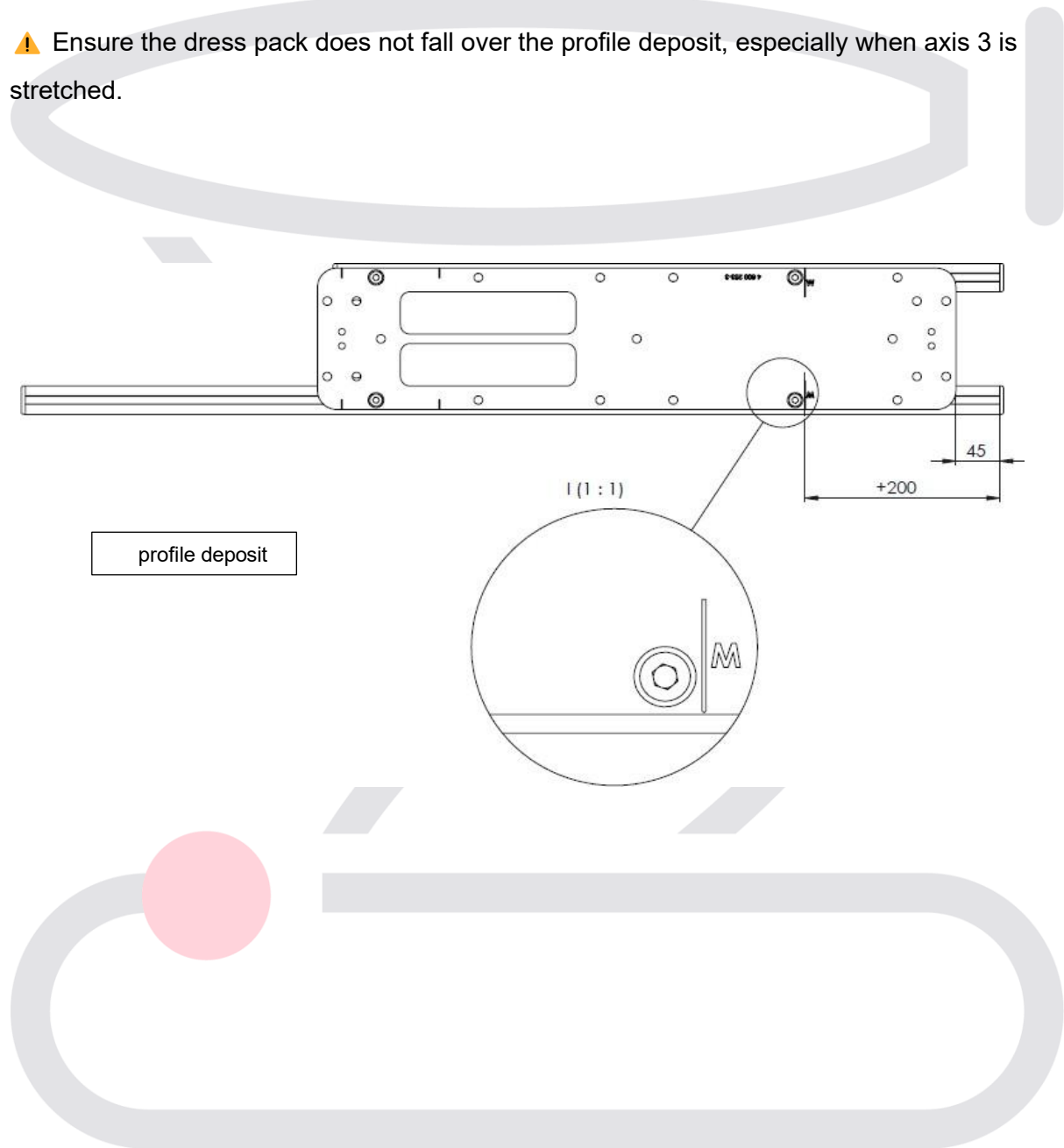

Adjustment – RoboRoc KK Frame

Optimization +100 mm:

- Loosen four M8 × 14 screws (SW 6)
- Move baseplate toward axis 6

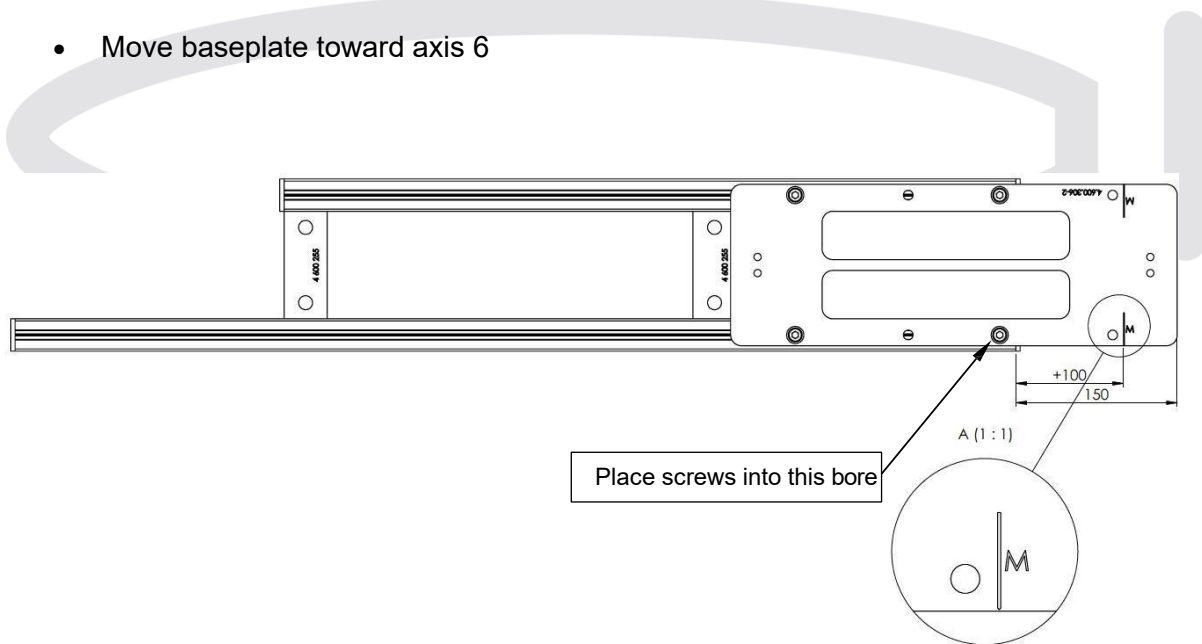

Optimization –100 mm:

- Move baseplate away from axis 6

Same tipping risk applies when axis 3 is stretched.

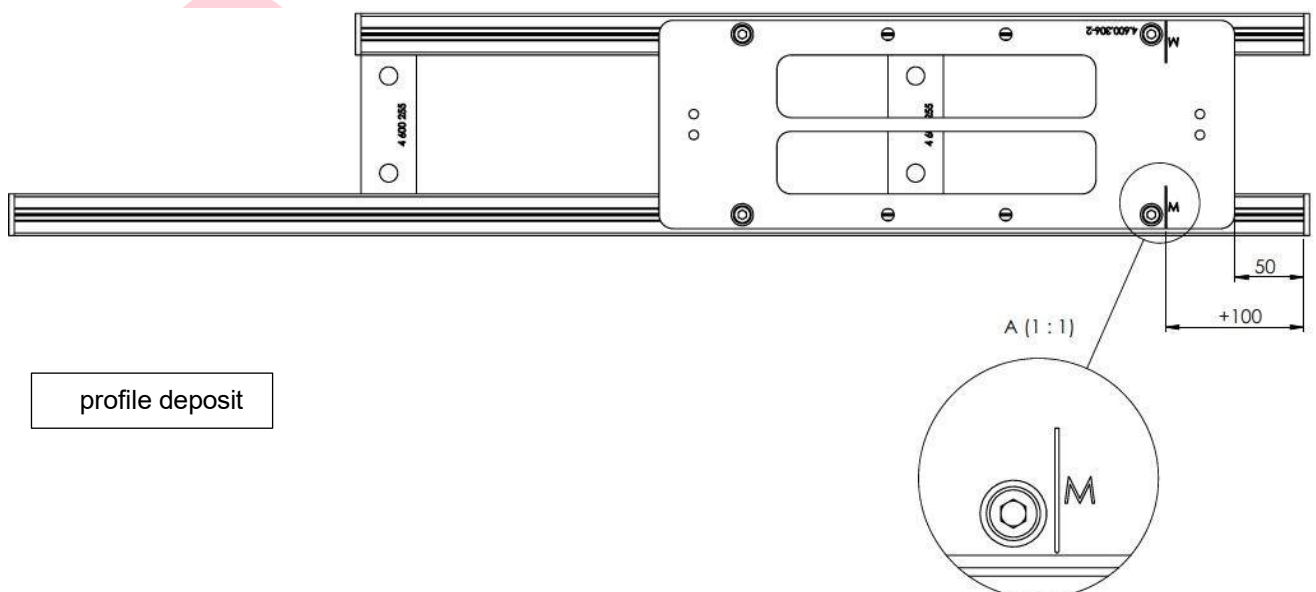

Adjustment – Bracket Axis 6

The axis 6 bracket allows adjustment in **four rotation axes and one linear axis**.

- **1st rotation axis:** 360° rotation, tighten SW 8 screws to **50 Nm**
- **2nd rotation / 1st linear axis:** tighten SW 8 screws to **40–50 Nm**
- **3rd rotation axis:**
 - Tighten baseplate screws to **20 Nm**
 - Tighten grub screws to **1.5 Nm**
- **4th rotation axis:**
 - Rotate tube clamps by 90°
 - Tighten to **50 Nm**

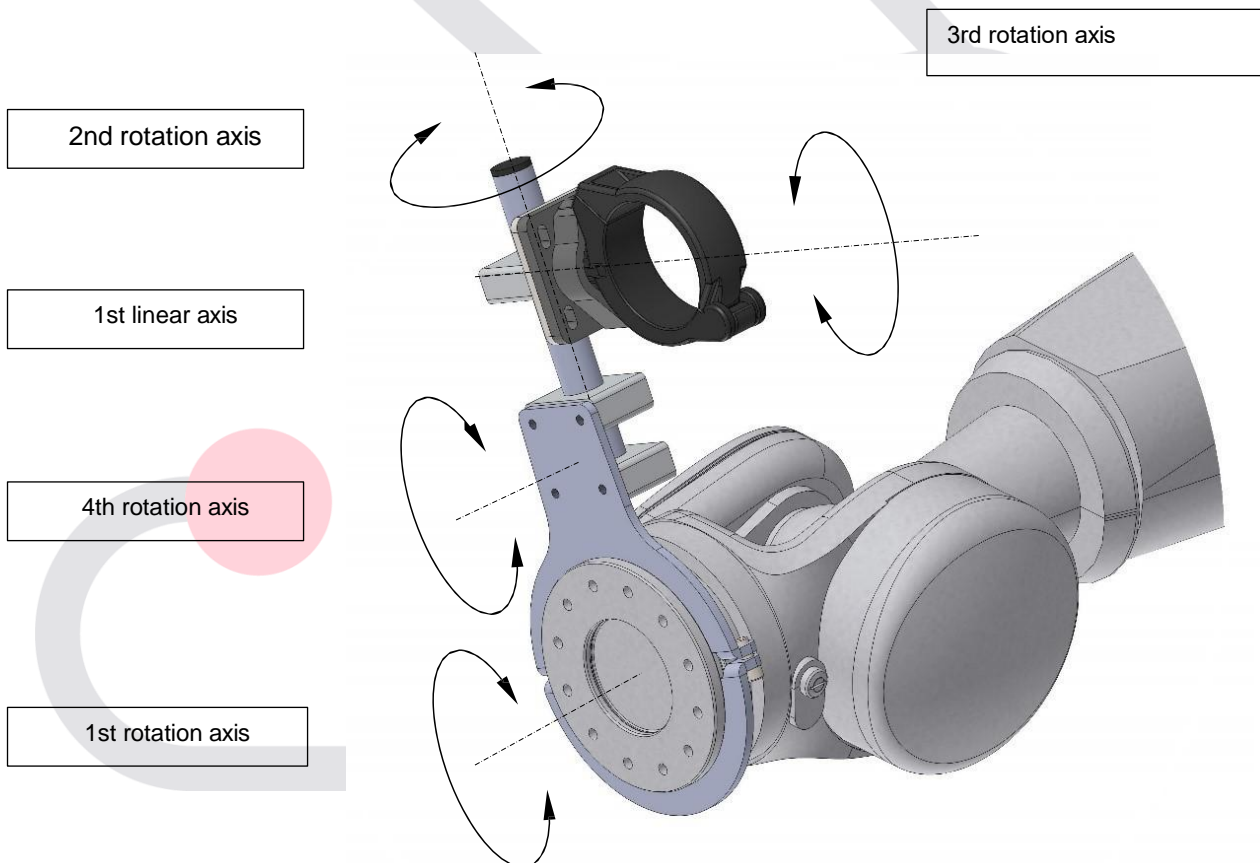

Adjustment – Protector and Connector

Protectors must be positioned so the corrugated tube does not rub.

- Loosen SW 3 screws
- Lever protector out with 4 mm screwdriver
- Reposition and fasten
- Protector must rotate freely on the corrugated tube

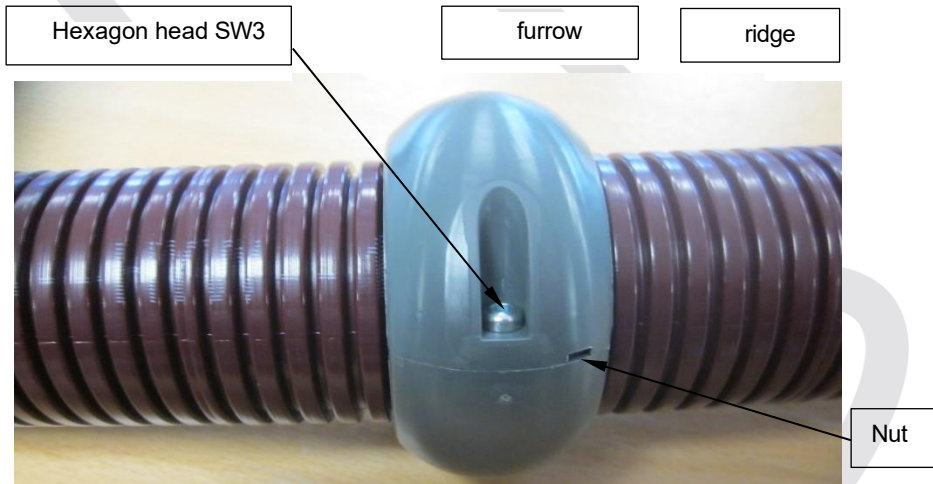

Protector and connector part numbers:

Art. No.	Description
4.362.100-1	Protector and connector NW36
4.482.100-1	Protector and connector NW48
4.702.100-1	Protector and connector NW70
4.902.100-1	Protector and connector NW90

Maintenance Instruction for Robot Dress Packs

Warranty is valid **only if the following requirements are met.**

Weekly visual inspection and function check (two-shift operation):

- Replace worn or damaged protectors/connectors
- Inspect corrugated tube; reposition protectors if required
- Check free movement of balls with trumpets; clean if necessary
- Check secure fit of supports
- Verify stud screw tightening
- Optimize routing if squashing, stretching, or catching occurs

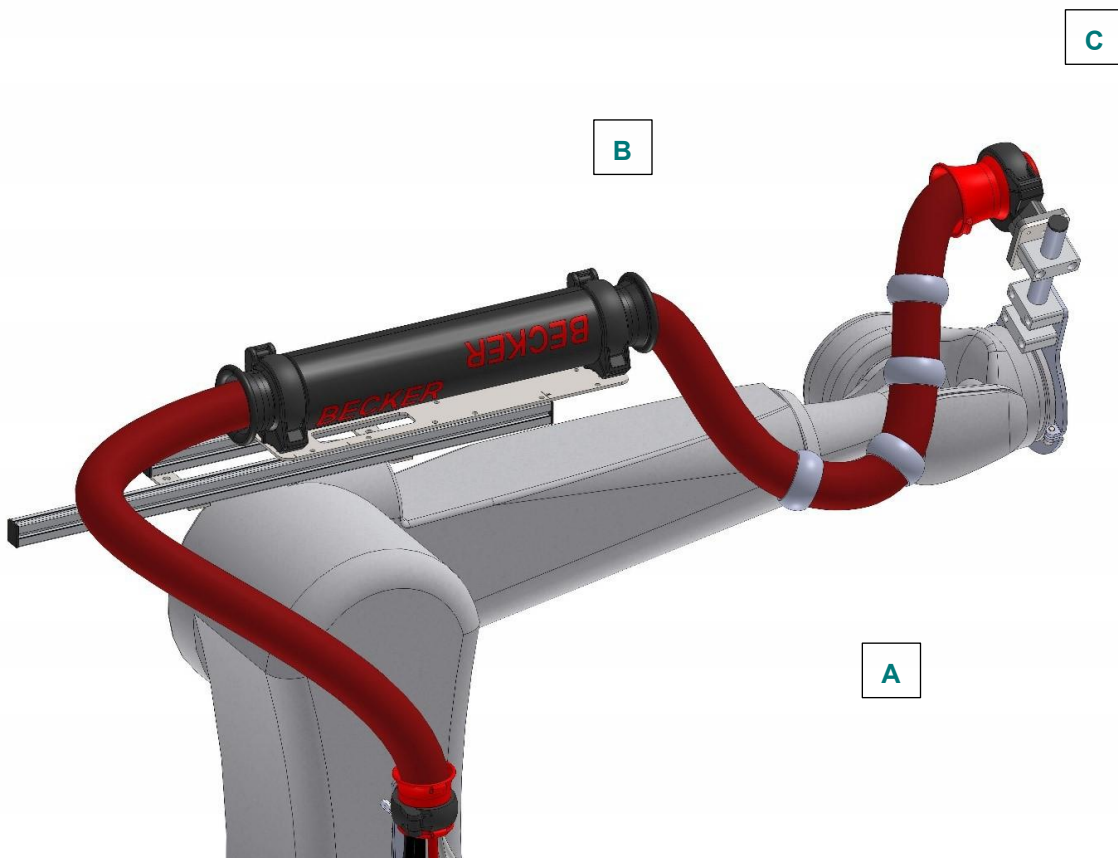

Maintenance & Repair

RoboRoc dress packs are **wear parts**.

Components subject to wear:

- Protectors/connectors
- Corrugated tube
- Supports
- Individual lines and hoses
- Balls, trumpets, RoboRoc tube

Repair measures

- **Protector:** replace if worn
- **Corrugated tube:**
 - Cut cleanly at ridge
 - Connect with protector/connector
 - Re-adjust spring tension or replace tube



Cut at the ridge

- **Supports:** replace if ball slips out
- **Supply lines:** replace if malfunctioning
- **Trumpets / balls / guides:** replace when worn

Replacing the **complete dress pack (axis 3–6)** may be faster than replacing individual lines and should be considered to minimize downtime.

Compliance and Verification

Verification includes:

- Visual inspection
- Functional motion testing
- Confirmation of stable routing behavior
- Verification of interference-free operation

Document Control & IP Notice

Protection notices according to DIN ISO 16016:

Reproduction, distribution, or utilization of this document without express authorization is prohibited.

All rights reserved in the event of patent, utility model, or design registration.